

IMPERIA T6 ZOOM SPOT

SURFACE MOUNT T6 METAL HALIDE

IMZ-SM
T6 MH

APPLICATION:

Retail and commercial accent and display lighting

CONSTRUCTION:

Die-cast aluminum lamp housing
Aluminum yoke
Steel mounting frame and mounting bars
On/Off lens cartridge allows for easy relamping
Powder coat paint
Comfort snoot provides simple press and rotate adjustment and additional shielding

OPTICS:

Adjustable narrow and wide range optics from high performance specular fluted, faceted and peened aluminum reflectors
Specially designed for T6 MH lamps
90° tilt, 358° rotation
Locking vertical adjustment

MOUNTING:

For use in T-grid or sheet rock ceilings

LABELING:

UL and CUL listed
Damp location



PROJECT :

TYPE :

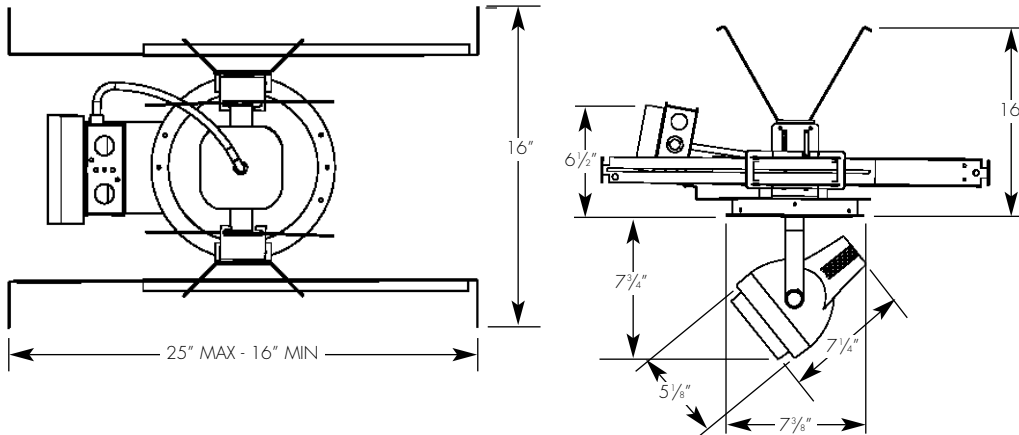

ELECTRICAL

Ballast	Voltage	39w		70w	
		Input watts	Amps*	Input watts	Amps*
Electronic	120v	44	.37	79	.67
	277v	46	.17	79	.29

*Data is for open circuit current
T6 G12 base metal halide, 39w and 70w

Amerlux reserves the right to change details that do not affect overall function and performance.

Ceiling cut out dimension: 6 3/4"

Imperia is also available in T4 lamping.
See specific Imperia T4 specification sheets for detail



ORDERING INFORMATION:

Model	Wattage	Lamp Type	Ballast	Finish	Voltage	Optics	Reflector Type	Options/Accessories
IMZ-SM	39 70	T6	E - electronic	WT - white textured - (other RAL)	120/277U	Z - Zoom field adjustable F - factory set	N - narrow (12°-24°) W - wide (30°-55°) CL - spot NF - narrow flood FL - flood WF - wide flood WWF - very wide flood SL - linear spread lens	SUN - sunrise optic reflector GOLD - ferric gold optic reflector HEX - hexcell louver (1/8" x 1/8")

Field Adjustable Example: IMZ-SM-39-T6-E-WT-120/277U-Z-N

Factory Set Example: IMZ-39-T6-E-WT-120/277U-F-FL

Cat #:

IMPERIA T6 ZOOM SPOT

SURFACE MOUNT T6 METAL HALIDE

IMZ-SM

T6 MH



TYPE:



FIXTURE DATA: For 70w data, multiply by 1.9

Complete photometric data (.ies format) available upon request.

T6 ZOOM 39W NARROW BEAM

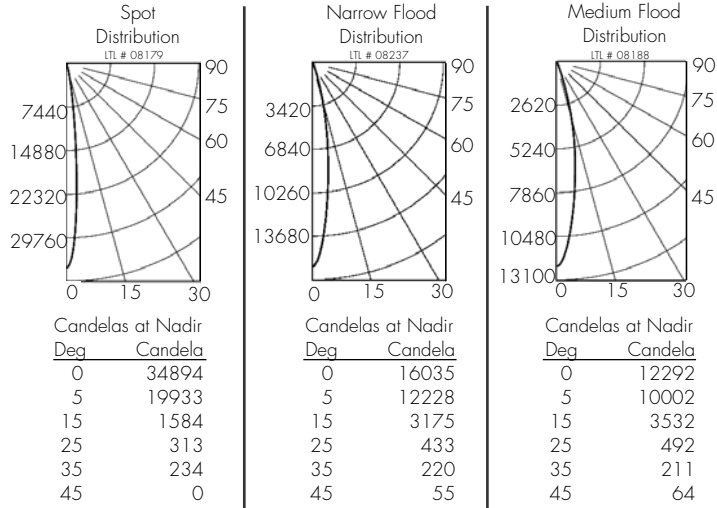

T6 ZOOM 39W WIDE BEAM

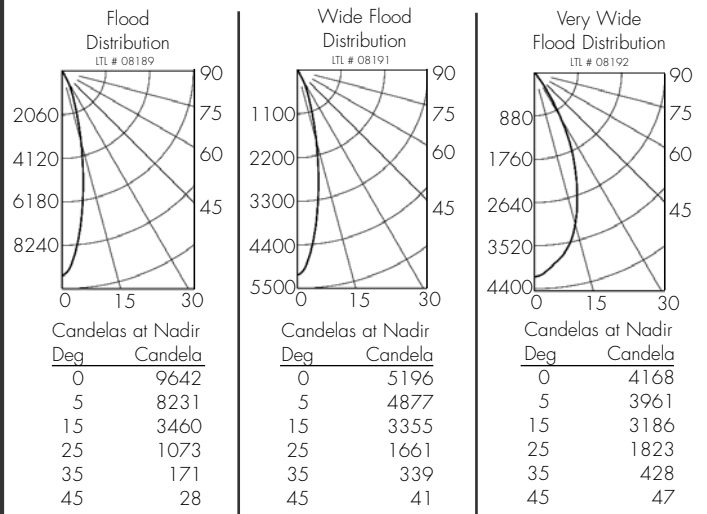

APPLICATION DATA:

Notes and Definitions:

Beam spread is to 50% center beam candlepower (CBCP).
 D=Distance to floor or wall.
 FC=Footcandles on floor or wall at center beam aiming location.
 L=Effective Visual Beam length in feet (50% of maximum footcandle level).
 W=Effective Visual Beam width in feet (50% of maximum footcandle level).
 CB=Distance across or down to center beam location.

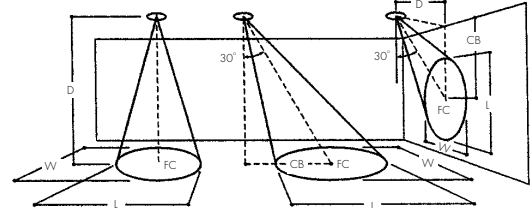

0° Aiming Angle
Horizontal
Footcandles



30° Aiming Angle
Horizontal
Footcandles



30° Aiming Angle
Vertical
Footcandles



60° Aiming Angle
Vertical
Footcandles

Beam Type	D	FC	L	W	CB	0° Aiming Angle Horizontal Footcandles					30° Aiming Angle Horizontal Footcandles					30° Aiming Angle Vertical Footcandles					60° Aiming Angle Vertical Footcandles				
						D	FC	L	W	CB	D	FC	L	W	CB	D	FC	L	W	CB	D	FC	L	W	CB
T6 ZOOM 39W NARROW BEAM SPOT	5.0'	1395	1.1	1.1		5.0'	905	1.3	1.2	2.9	3.0'	526	2.2	1.1	4.7	3.0'	2484	0.8	0.7	1.8	3.0'	2484	0.8	0.7	1.8
	7.5'	620	1.4	1.4		7.5'	403	2.0	1.6	4.3	4.0'	293	2.9	1.6	6.2	4.0'	1423	1.4	0.9	2.3	4.0'	1423	1.4	0.9	2.3
	10.0'	348	1.9	1.9		10.0'	226	2.7	2.4	5.6	5.0'	187	3.6	1.9	8.2	5.0'	908	1.3	1.2	2.7	5.0'	908	1.3	1.2	2.7
	12.5'	223	2.5	2.5		12.5'	145	3.3	2.9	7.2	6.0'	131	4.3	2.3	9.8	6.0'	622	1.6	1.4	3.3	6.0'	622	1.6	1.4	3.3
T6 ZOOM 39W NARROW BEAM NARROW FLOOD	5.0'	641	1.5	1.5		5.0'	417	2.1	1.7	2.9	3.0'	255	3.1	1.8	4.2	3.0'	1139	1.2	1.1	1.8	3.0'	1139	1.2	1.1	1.8
	7.5'	285	2.4	2.4		7.5'	185	3.1	2.7	4.4	4.0'	144	4.1	2.4	5.7	4.0'	650	1.7	1.5	2.3	4.0'	650	1.7	1.5	2.3
	10.0'	160	3.2	3.2		10.0'	104	4.1	3.6	5.8	5.0'	93	5.1	2.9	7.2	5.0'	415	2.0	1.8	2.8	5.0'	415	2.0	1.8	2.8
	12.5'	102	3.8	3.8		12.5'	67	5.1	4.4	7.2	6.0'	64	6.2	3.5	8.8	6.0'	288	2.5	2.2	3.2	6.0'	288	2.5	2.2	3.2
T6 ZOOM 39W NARROW BEAM MEDIUM FLOOD	5.0'	491	1.8	1.8		5.0'	319	2.4	2.1	2.9	3.0'	209	3.3	2.0	4.3	3.0'	874	1.4	1.3	1.8	3.0'	874	1.4	1.3	1.8
	7.5'	218	2.8	2.8		7.5'	141	3.6	3.2	4.3	4.0'	117	4.4	2.7	5.7	4.0'	501	1.9	1.7	2.2	4.0'	501	1.9	1.7	2.2
	10.0'	122	3.6	3.6		10.0'	80	4.7	4.2	5.7	5.0'	75	5.5	3.4	6.7	5.0'	321	2.4	2.1	2.7	5.0'	321	2.4	2.1	2.7
	12.5'	79	4.5	4.5		12.5'	51	5.9	5.2	7.2	6.0'	52	6.6	4.0	8.2	6.0'	223	2.8	2.5	3.2	6.0'	223	2.8	2.5	3.2
T6 ZOOM 39W WIDE BEAM FLOOD	5.0'	385	2.0	2.0		5.0'	250	2.7	2.4	2.9	3.0'	173	3.7	2.2	4.3	3.0'	687	1.6	1.4	1.7	3.0'	687	1.6	1.4	1.7
	7.5'	171	3.1	3.1		7.5'	111	4.0	3.5	4.3	4.0'	99	4.8	2.9	5.2	4.0'	394	2.1	1.9	2.2	4.0'	394	2.1	1.9	2.2
	10.0'	96	4.0	4.0		10.0'	63	5.3	4.6	5.8	5.0'	63	6.0	3.6	6.7	5.0'	254	2.6	2.3	2.8	5.0'	254	2.6	2.3	2.8
	12.5'	62	5.0	5.0		12.5'	41	6.5	5.7	6.2	6.0'	44	7.2	4.3	7.8	6.0'	177	3.1	2.8	3.2	6.0'	177	3.1	2.8	3.2
T6 ZOOM 39W WIDE BEAM WIDE FLOOD	5.0'	207	3.1	3.1		5.0'	140	3.9	3.4	1.9	3.0'	130	3.7	2.8	3.3	3.0'	400	2.3	2.0	1.3	3.0'	400	2.3	2.0	1.3
	7.5'	92	4.6	4.6		7.5'	64	5.6	5.2	3.3	4.0'	74	4.9	3.8	4.3	4.0'	226	2.9	2.8	1.7	4.0'	226	2.9	2.8	1.7
	10.0'	52	6.2	6.2		10.0'	36	7.5	6.9	4.8	5.0'	47	6.1	4.7	5.2	5.0'	145	3.7	3.4	2.2	5.0'	145	3.7	3.4	2.2
	12.5'	33	7.6	7.6		12.5'	23	9.4	8.7	6.2	6.0'	33	7.3	5.6	6.2	6.0'	100	4.5	4.2	2.8	6.0'	100	4.5	4.2	2.8
T6 ZOOM 39W WIDE BEAM VERY WIDE FLOOD	5.0'	166	3.7	3.7		5.0'	121	4.1	3.9	1.9	3.0'	127	3.4	3.0	2.8	3.0'	335	2.5	2.4	1.2	3.0'	335	2.5	2.4	1.2
	7.5'	74	5.5	5.5		7.5'	53	6.2	5.9	2.4	4.0'	72	4.5	4.0	3.7	4.0'	187	3.3	3.2	1.3	4.0'	187	3.3	3.2	1.3
	10.0'	42	7.3	7.3		10.0'	31	8.2	7.9	3.7	5.0'	46	5.6	5.0	4.7	5.0'	121	4.1	4.0	1.8	5.0'	121	4.1	4.0	1.8
	12.5'	7	9.1	9.1		12.5'	19	10.3	9.9	4.2	6.0'	32	6.7	6.0	5.7	6.0'	85	4.9	4.8	2.2	6.0'	85	4.9	4.8	2.2