

SVA SHALLOW VERTICALLY ADJUSTABLE

SVA
ED17 MH

APPLICATION:

Retail and commercial ambient, accent and display lighting

CONSTRUCTION:

Rolled steel housing painted matte black
Stamped steel mounting plate and mounting bars

OPTICS:

Spun and fluted semi-specular aluminum reflector,
Spun semi-diffuse clear aluminum aperture cone with white flange (standard)
Glass lens with various distributions
ED17 ceramic metal halide lamps.

MOUNTING:

For use in T-grid or sheet rock ceilings

LABELING:

UL and CUL listed
Damp location



PROJECT:

TYPE:

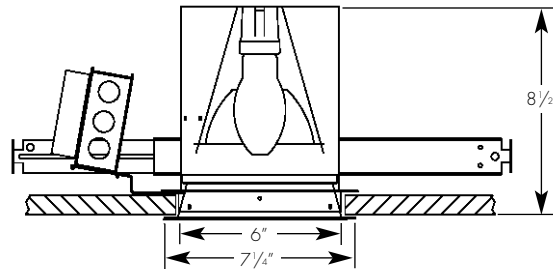
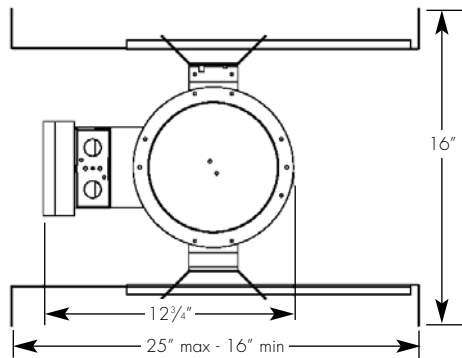

Ceiling cut out dimension: 6 3/4"

ELECTRICAL

Ballast	Voltage	Lamping			
		70w		100w	
		Input watts	Amps*	Input watts	Amps*
Electronic	120v	79	.67	110	.90
	277v	79	.29	110	.41

*Data is for open circuit current
ED-17 medium base metal halide, 70w and 100w

Amerlux reserves the right to change details that do not affect overall function and performance.



ORDERING INFORMATION:

Model	Wattage	Lamp Type	Ballast	Aperture Cone Finish	Trim Finish	Voltage	Beam Spreads	Options/ Accessories
SVA	70 100	17 - ED17	E - electronic	SD - semi-diffuse	W - white C - clear (same as aperture)	120/277U	CL - spot NF - narrow flood FL - flood WF - wide flood SL - linear spread lens	SUN - sunrise optic reflector GOLD - ferric gold optic reflector

Example: SVA-70-17-E-SD-W-120/277U-FL

Cat #:

SVA SHALLOW VERTICALLY ADJUSTABLE

SVA
ED17 MH



TYPE :



FIXTURE DATA:

For 100w data multiply by 1.5

Complete photometric data (.ies format) available upon request.

70W ED-17 MH

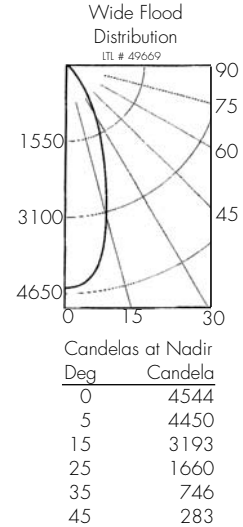
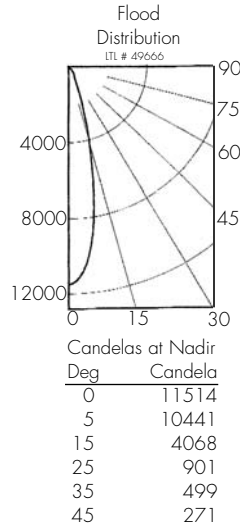
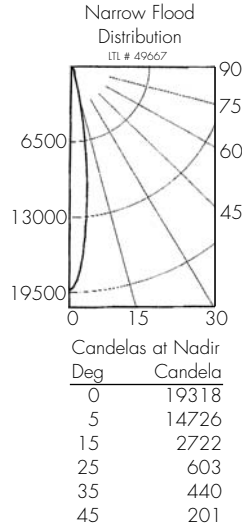
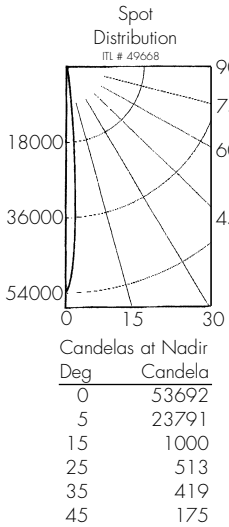

APPLICATION DATA:

Notes and Definitions:

Beam spread is to 50% center beam candlepower (CBCP).
 D=Distance to floor or wall.
 FC=Footcandles on floor or wall at center beam aiming location.
 L=Effective Visual Beam length in feet (50% of maximum footcandle level).
 W=Effective Visual Beam width in feet (50% of maximum footcandle level).
 CB=Distance across or down to center beam location.

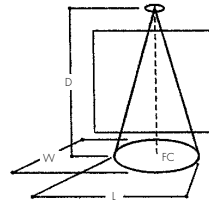

	D	FC	L	W
SPOT	5.0'	2147	1.0	1.0
	7.5'	954	1.2	1.2
	10.0'	536	1.5	1.5
	12.5'	343	2.0	2.0
NARROW FLOOD	5.0'	772	1.4	1.4
	7.5'	343	2.2	2.2
	10.0'	198	2.9	2.9
	12.5'	123	3.7	3.7
FLOOD	5.0'	460	2.2	2.2
	7.5'	204	3.2	3.2
	10.0'	115	4.2	4.2
	12.5'	74	5.3	5.3
WIDE FLOOD	5.0'	181	3.4	3.4
	7.5'	81	5.0	5.0
	10.0'	45	6.6	6.6
	12.5'	29	8.1	8.1