

# COMPACT BUSWAY

## 40, 50 & 60 AMP HOUSING

B 40, B 50 &  
B 60 C  
HOUSING

Each Track Busway housing section consists of an extruded aluminum housing with an insulated strip containing copper conductors mounted on the top interior wall. The aluminum extrusion acts as a 100% ground path meeting UL 857 Standard and complies with applicable paragraphs of Section 250 of the NEC. Each housing section has an open access slot over its entire length for the insertion of snap-in plug-in units. Configurations include 2 and 4 pole varieties, rated at 40/50/60 Amp continuous duty, 480/277 Volts max. Housing sections are connected together using snap-in, in-line connectors and plate type housing couplers. Sections are supported every 10 ft max. and can support 75lbs hanging weight between vertical supports.

Four-pole Busway is normally used in phase/4-wire power systems. Four-pole Busway may be used for 2 independent single phase circuits at different voltages. Sections can be factory cut to any length.

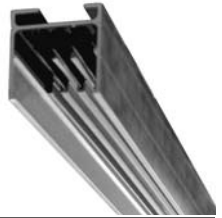

PROJECT :  
  
TYPE :

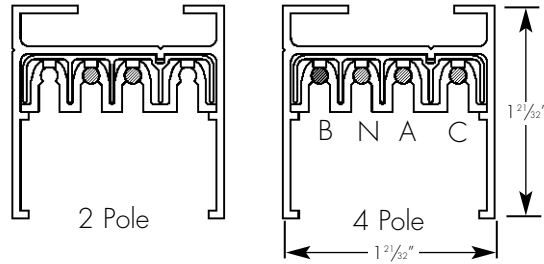

### Catalog Number Sequence

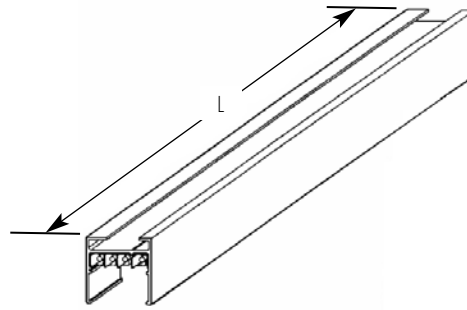
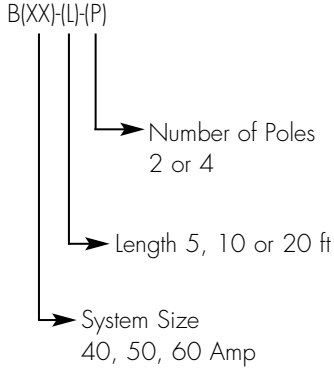

### ORDERING INFORMATION:

Model	Description	Length*	Weight
B40-5-2 or 4	40 amp, 2 or 4 pole	5'	3.5/4 lb
B40-10-2 or 4	40 amp, 2 or 4 pole	10'	7/8 lb
B40-20-2 or 4	40 amp, 2 or 4 pole	20'	13/15 lb
B50-5-2 or 4	50 amp, 2 or 4 pole	5'	3.5/4 lb
B50-10-2 or 4	50 amp, 2 or 4 pole	10'	7/8 lb
B50-20-2 or 4	50 amp, 2 or 4 pole	20'	13/15 lb
B60C-5-2 or 4	60 amp, 2 or 4 pole	5'	4/4.5 lb
B60C-10-2 or 4	60 amp, 2 or 4 pole	10'	8/9 lb
B60C-20-2 or 4	60 amp, 2 or 4 pole	20'	15/17 lb

Example: B40-5-4

Cat #:

\*End section can be field cut to any length

# COMPACT BUSWAY

## ELBOW, TEE & CROSSOVER

B 40, B 50 &  
B 60 C  
ELBOW, TEE &  
CROSSOVER

### Elbow Connector

Factory pre-assembled elbow sections are used for making a 90-degree turn. Elbows are connected to Busway sections electrically by means of built-in bus connectors. Connectors are installed by "snapping" into position with housing section butted together. Connectors are polarized to prevent phase mismatch. Housings are then mechanically joined via couplers, ordered separately. Refer to LAYOUT for polarization issues before making final selection.

### Tee Connector

Similar to Elbow Connectors, Tee Connectors are used for connecting branch housing sections at 90 degrees to the main run. Refer to LAYOUT for polarization issues before making final selection.

### Crossover

Typically used for grid designs. Four (4) couplers (ordered separately) are required. Refer to LAYOUT for selection.

PROJECT :  
  
TYPE :



Elbow Section  
(2 couplers required,  
order separately)

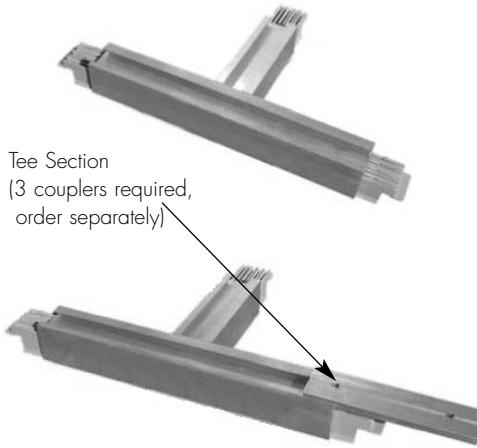

Tee Section  
(3 couplers required,  
order separately)

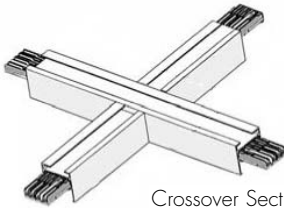

Crossover Section (same  
plane) (4 couplers required,  
order separately)

**NOTE: Elbow, Tee and Crossover sections can connect only to adjoining straight housing sections**

**Please refer to LAYOUT prior to final product selection**

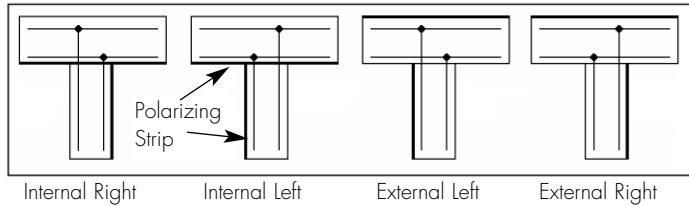

### ORDERING INFORMATION:

Model	Description	Weight	Catalog Number Sequence
EL40-2-(IH or EH)	Elbow Connector, 40 amp, 2 pole	0.5 lb	<b>Catalog Number Sequence</b> (XX)(AA)-(P)-(DIR) ↓      ↓      ↓ System Size    System Poles    Direction (refer to layout) Connector Type: EL - elbow BT - busway tee BC - in-line connector X - crossover
EL40-4-(IH or EH)	Elbow Connector, 40 amp, 4 pole	0.5 lb	
EL50-2-(IH or EH)	Elbow Connector, 50 amp, 2 pole	0.5 lb	
EL50-4-(IH or EH)	Elbow Connector, 50 amp, 4 pole	0.5 lb	
EL60C-2-(IH or EH)	Elbow Connector, 60 amp, 2 pole	0.5 lb	
EL60C-4-(IH or EH)	Elbow Connector, 60 amp, 4 pole	0.5 lb	
BT40-4IR	Tee Connector, 4 pole, Internal Right	1.0 lb	
BT50-4IL	Tee Connector, 4 pole, Internal Left	1.0 lb	
BT60C-4ER	Tee Connector, 4 pole, External Right	1.0 lb	
BT60C-4EL	Tee Connector, 4 pole, External Left	1.0 lb	
X40-2 or 4	Crossover, 40 amp 2 or 4 pole	1.5 lb	
X50-2 or 4	Crossover 50 amp 2 or 4 pole	1.5 lb	
X60C-2 or 4	Crossover 60 amp 2 or 4 pole	1.5 lb	
Example: EL40-2-IH			
Cat #:			

# COMPACT BUSWAY

## IN-LINE BUS CONNECTORS

B40, B50 &  
B60C  
IN-LINE BUS  
CONNECTORS

### In-Line Connector

Sections of Busway are joined electrically by means of an in-line connector. The connector is installed by "snapping" into position with housing section butted together. All in-line bus connectors are polarized to prevent phase mismatch. Housing are mechanically joined via a coupler, ordered separately. The mechanical coupler also acts as 100% ground connection.

PROJECT:  
  
TYPE:

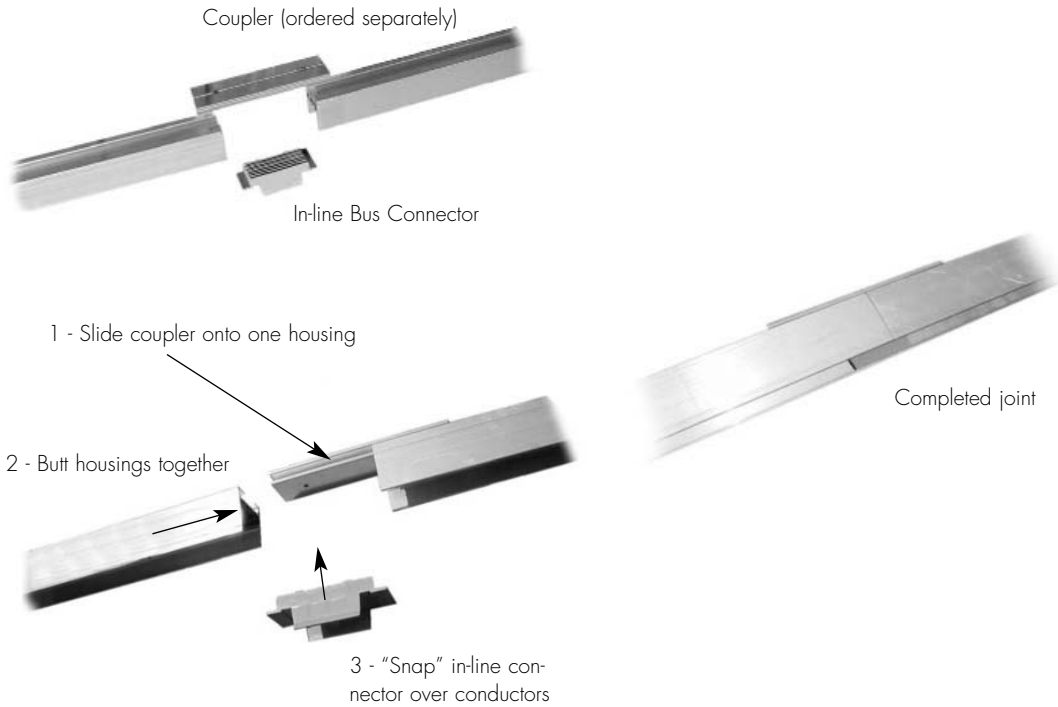

### ORDERING INFORMATION:

Model	Description	Weight
BC50-2*	In-line Connector, 2 pole, 50 amp max	0.1 lb
BC50-4*	In-line Connector, 4 pole, 50 amp max	0.1 lb
BC60C-2	In-line Connector, 2 pole, 60 amp max	0.1 lb
BC60C-4	In-line Connector, 4 pole, 60 amp max	0.1 lb

\*Used for both 40 and 50 amp systems

### Catalog Number Sequence

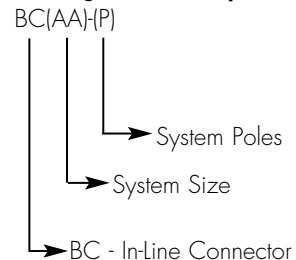

Example: BC50-2

Cat #:

# COMPACT BUSWAY

## CONNECTION ACCESSORIES

B40, B50 &  
B60C  
CONNECTION  
ACCESSORIES

### END CAP

For insulating female end of Busway.

### COUPLERS

#### Plate Type

For concealed connecting Busway sections. One required.

### CLOSURE STRIP

Made of white, rigid PVC, the closure strip is used to close the continuous access slot of the Busway. It may be used for aesthetic purposes, for keeping dust and dirt from entering the Busway or as an added safety measure. It is easily cut to length in the field to be installed between plug-in units.

PROJECT:

TYPE:

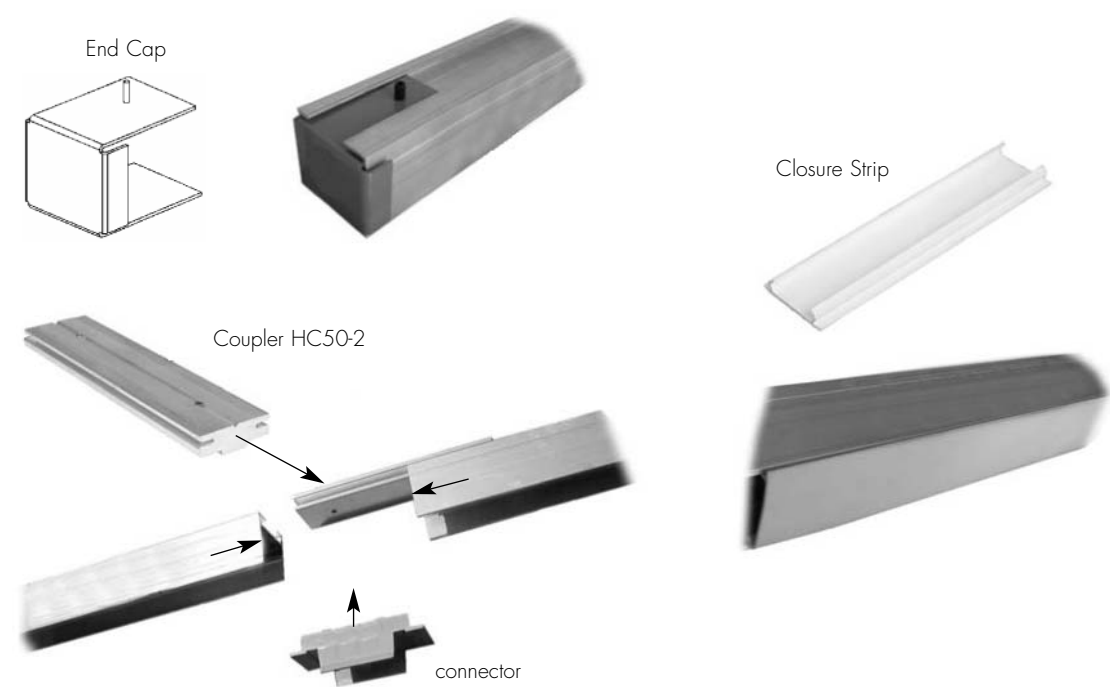

### ORDERING INFORMATION:

Model	Description	Weight
EC50	End Cap	0.2 lb
HC50-2	Housing Coupler	0.8 lb
CS50	Closure Strip	

Example: EC50

Cat #:

# COMPACT BUSWAY

## SUPPORT HARDWARE

B40, B50 &  
B60C  
SUPPORT  
HARDWARE

### THREADED ROD HANGER

For mounting to 3/8"-16 threaded rod. Can be inserted anywhere along full access top slot of Busway. Typical hanger support spacing every 10 ft maximum.

### STANDARD

For mounting to strut or other flat surfaces. Twist-in design allows inserting anywhere along top full access slot.

### CABLE

For mounting to 1/16" or 3/32" aircraft cable with easy grip clamp assembly. Cable is not included.

### T-BAR SUSPENDED CEILING

For mounting to inverted T-bar. Clip locks onto T-bar and Busway connected to stud on clip.

### WEIGHT HOOK

Can be used as a hanger to suspend Busway from chains or cables. Can also be used to hang loads up to 50 lbs under the Busway, such as light fixtures, tools and balancers.

PROJECT:  
  
TYPE:

RHB-3 Threaded Rod Hanger

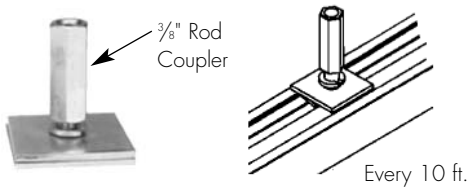

THB-3 Standard Hanger

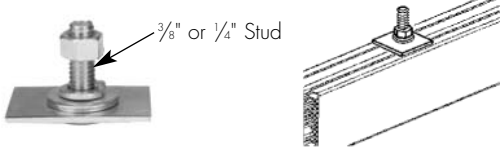

THB-5 T-Bar Clip

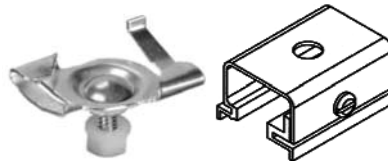

WHO-50 Weight Hook

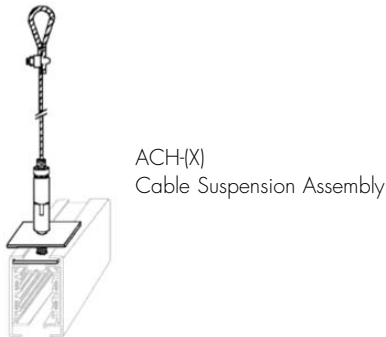
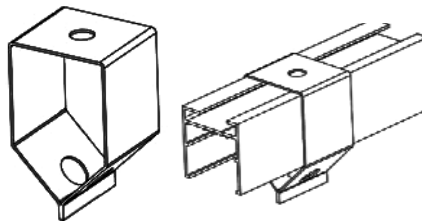

ACH(X)  
Cable Suspension Assembly



### ORDERING INFORMATION:

Model	Description	Weight
RHB-3	Threaded Rod Hanger	0.3 lb
THB-3	Standard Hanger	0.2 lb
ACH-1 (1/16" cable)	Cable Suspension Assembly	0.2 lb
ACH-2 (3/32" cable)	Cable Suspension Assembly	0.2 lb
THB-5	T-bar Ceiling Clip	0.1 lb
WHR-50	Weighted Hook	0.2 lb

Example: THB-3

Cat #:

# COMPACT BUSWAY

## POWER FEED UNITS

B 40, B 50 &  
B 60 C  
POWER FEED UNITS

### End Power Feed - EF

Consists of a steel junction box with removable side, a connector to insert into the Busway run and terminal block for field connections. Unit is bolted to first Busway section. Rated at 480/277 Volts.

### Center Feed - CF

Consists of a 2 ft section of Busway with connectors at both ends to connect to adjacent Busway sections and junction box mounted on top with terminal block for field connection.

### End Feed Concealed - EFC

Provide an inconspicuous means for connecting power. Consists of a 1 foot section of Busway with connector mounted inside and wire lead exiting through end cap. A 1" conduit mounting adapter is included. Housing Coupler (HC50-2, ordered separately) is used to connect to Busway section.

### Pendant Wired - PW

Consists of 1 ft Busway section with 1" conduit size access hole for access to connection leads inside Busway. 1" conduit mounting adapter included.

PROJECT :

TYPE :

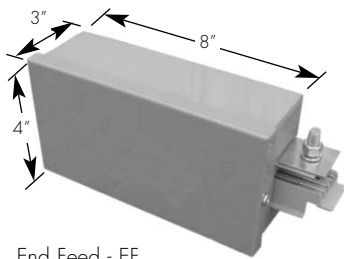

End Feed - EF



End Feed installed

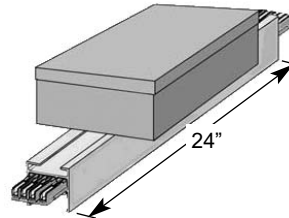

Center Feed -CF

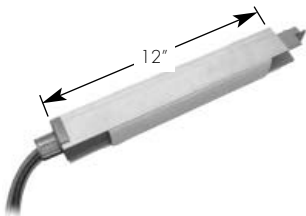

End Feed Concealed- EFC



Installed

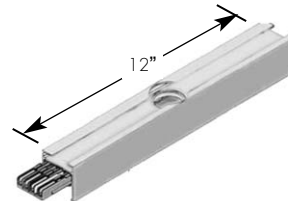

Pendant Wired - PW



### ORDERING INFORMATION:

Model	Description	Weight
EF40-2 or 4	End Feed, 40 amp	3.3 lb
EF50-2 or 4	End Feed, 50 amp	3.3 lb
EF60C-2 or 4	End Feed, 60 amp	3.3 lb
EFC40-2 or 4	End Feed Concealed, 40 amp	2 lb
EFC50-2 or 4	End Feed Concealed, 50 amp	2 lb
EFC60C-2 or 4	End Feed Concealed, 60 amp	2 lb
CFB40-2 or 4	Center Feed, 40 amp	5 lb
CFB50-2 or 4	Center Feed, 50 amp	5 lb
CFB60C-2 or 4	Center Feed, 60 amp	5 lb
PW40-2 or 4	Pendant Wired, 40 amp	2 lb
PW50-2 or 4	Pendant Wired, 50 amp	2 lb
PW60C-2 or 4	Pendant Wired, 60 amp	2 lb

### Catalog Number Sequence

(XX)(AA)-(X)

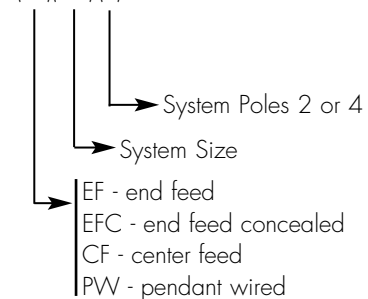

Example: EFC50-4

Cat #:

# COMPACT BUSWAY

## POWER PLUG-IN UNITS

B 40, B 50 &  
B 60C  
POWER PLUG-IN  
UNITS

Outlet Plug-In units are used to tap off power from the Busway. All plug-in units are equipped with a special plug head called a "Starjack" which "snaps" into the Busway continuous slot to make the spring-loaded connection. The installer simply inserts the unit into the Busway until a "clicking" sound is heard on each side of the connector. The snap-in connector provides ground connection for the box and load. All plug-in units are polarized to inhibit reverse installation.

### A. Outlet or Junction Box

Standard unit consists of J-box with connector, cover, ground lug and wire nuts. Optional fuse holders available.

### B. Receptacle Box

Standard unit consists of J-box with connector, NEMA 5-15 or 5-20 duplex receptacle, fuse and fuse holder. Other NEMA configurations available.

PROJECT :

TYPE :

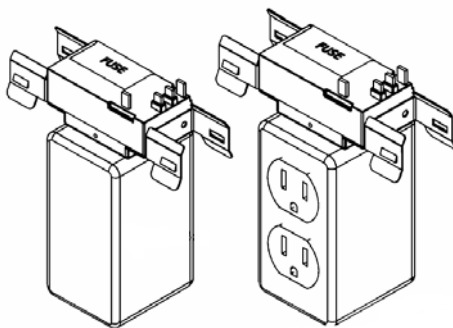

Outlet or  
Junction Box

Receptacle Box  
(always with fuse)

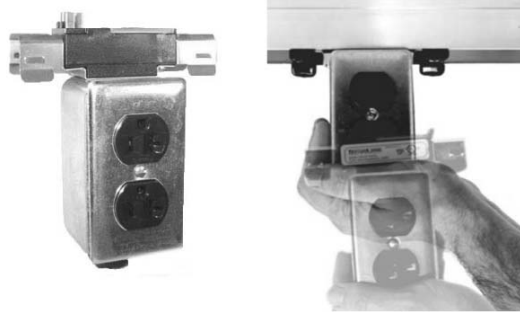

### ORDERING INFORMATION:

Model	Description	Weight
OB50-30-2	Junction Box, 30 amp, 2 pole*	1.2 lb
OB50-30-4	Junction Box, 30 amp, 4 pole*	1.2 lb
OB50-30-4-XF	Junction Box, 30 amp, 4 pole*	1.3 lb
DRF50-20-A	Duplex, 20 amp, 2 pole, A phase*	1.4 lb
DRF50-20-B	Duplex, 20 amp, 2 pole, B phase*	1.4 lb
DRF50-20-C	Duplex, 20 amp, 2 pole, C phase*	1.4 lb

\*Used in 40, 50 and 60C systems

### Catalog Number Sequence

(XXX)-(A)-(P)-XF

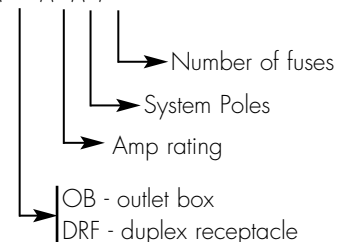

Example: DRF-50-20-A

Cat #:

# COMPACT BUSWAY

## DROP CORD PLUG-IN

B 40, B 50 &  
B 60C  
DROP CORD PLUG-IN

### Drop Cord Assembly

Shipped assembled complete from the factory based on part number selection including cord, fuses, and wiring device. Drop Cord assemblies with connector type (C) wiring device include a wire mesh cord grip at outlet of plug-in box. All other assemblies include wire mesh cord grips at both end of cord. SJO cord is used in all assemblies. Other NEMA configurations available.

### Labeling

UL and CUL listed

PROJECT:

TYPE:

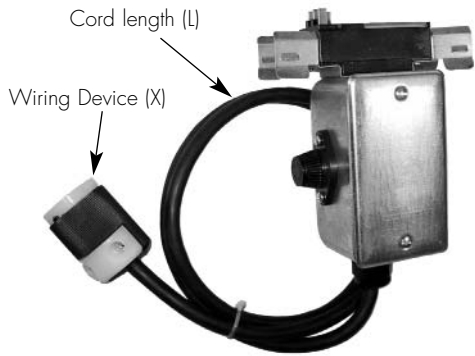

Wiring Device (X)

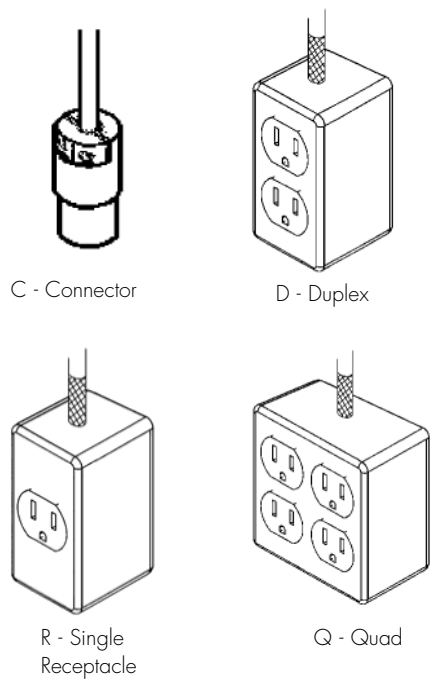

### ORDERING INFORMATION:

Model	Description
-------	-------------

DC50-10-520D-4	10' Drop Cord with NEMA 5-20 Duplex on end, for 4 pole system
DC50-15-L520C-2	15' Drop Cord with NEMA L5-20 (locking type) Connector on end, for 2 pole system
DC50-8-L630R-4	8' Drop Cord with NEMA L6-30 (locking type) single Receptacle (J-Box) on end, for 4 pole system

(Many more available)

Example: DC50-15-L520C-2

Cat #:

### Catalog Number Sequence

DC50-(L)-(NEMA)(X)-(Y)

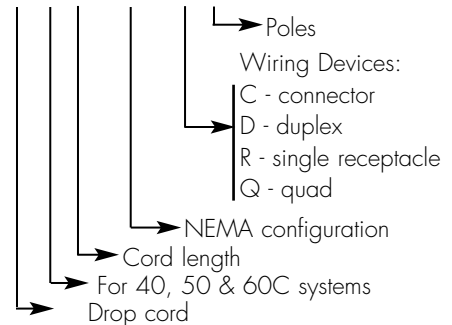

# COMPACT BUSWAY

## CIRCUIT BREAKER PLUG-IN

B 40, B 50 &  
B 60 C  
CIRCUIT BREAKER  
PLUG-IN

### Circuit Breaker

Consists of a full-size junction box with hinged lid, plug head and an externally operated circuit breaker. The circuit breaker plug-in is inserted into the busway until mounting clips "snap" into place. The units are normally supplied with breakers installed. Units can be supplied with mounting plate only to allow installation of snap-on breakers in the field. Optional factory-installed receptacles can be added. Circuit breakers can be 15 to 30 amps, 240 volts, and 1, 2 or 3 poles. Units with UL Listed multiple breakers are available. Units include copper grounding lug in the box that fits up to #6 wire, mounting tabs and mounting hardware to secure unit to Busway. Units have 1/2" and 3/4" conduit knockouts on 3 sides.

PROJECT :  
  
TYPE :

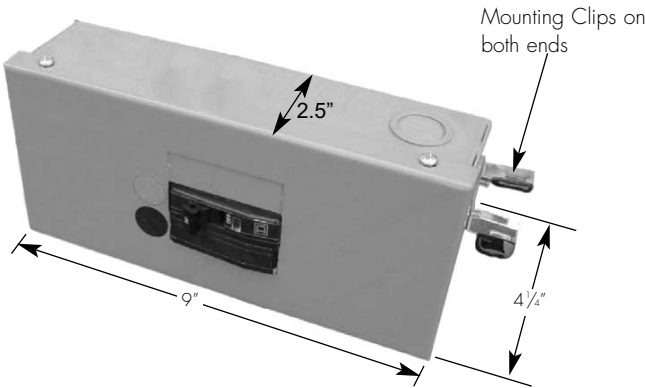

Circuit Breaker installed on Amerlux Busway



### ORDERING INFORMATION:

Model	Description	Weight
-------	-------------	--------

CB50-WV-1-240-2	1 pole Circuit Breaker, 2 pole Busway	3.3 lb
CB50-WV-2-240-2	2 pole Circuit Breaker, 2 pole Busway	3.7 lb
CB50-WV-1-240-4	1 pole Circuit Breaker, 4 pole Busway	3.3 lb
CB50-WV-2-240-4	2 pole Circuit Breaker, 4 pole Busway	3.7 lb
CB50-WV-3-240-4	3 pole Circuit Breaker, 4 pole Busway	4.2 lb

"WV" - specify the ampere rating, 15 to 30 amps

Example: CB50-WV-2-240-2

Cat #:

### Catalog Number Sequence

(XX)50-(wv)-(p)-(volt)-(P)

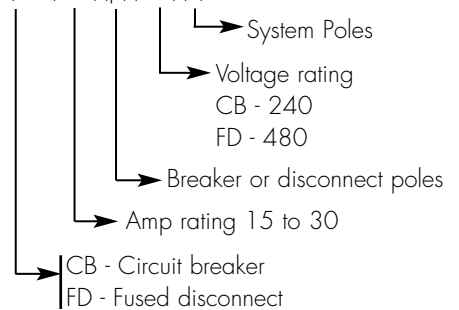

# COMPACT BUSWAY

## FUSED DISCONNECT PLUG-IN

B40, B50 &  
B60C  
FUSED DISCONNECT  
PLUG-IN

### Fused Disconnect

Units provide a 3-pole fuse block for Class CC fuses (ordered separately) with an external floor operable disconnect. The disconnect mechanism is floor operable with chains or a stick. Unit is rated at 30 Amps, 480/277 Volts.

PROJECT:

TYPE:

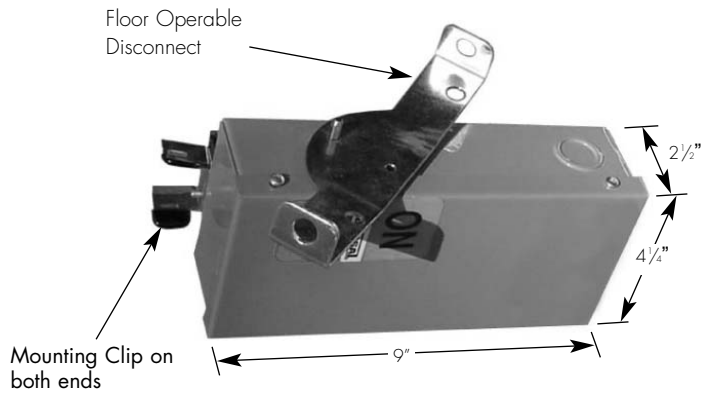

Fused Disconnect installed on Amerlux Busway



### ORDERING INFORMATION:

Model	Description	Weight
-------	-------------	--------

FD50-30-3-480-4	Fused Disconnect, 30A, 3P, 480V for 4 pole Busway	4.2 lb
-----------------	---	--------

### Catalog Number Sequence

(FD)50-(ww)-(p)-(480)-(P)

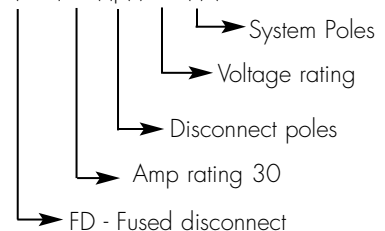

Example: FD50-30-3-480-4

Cat #:

# COMPACT BUSWAY

## INTERNAL PLUG-IN

B 40, B 50 &  
B 60C  
INTERNAL PLUG-IN

Ideal for applications where the plug head should not be visible such as light fixtures and retail/commercial areas. This Internal Plug "clicks" into the Busway section and provides a mounting plate for light fixture connection. The unit inserts into the Busway continuous slot and snaps into place, making the mechanical, electrical and grounding connections. Units are polarized to inhibit reverse installation.

Internal plugs are available in ratings of 20 and 30 amps, 480/277 volts, fusible or non-fusible. The 20 amp version utilizes high temperature wire for ballast and fixture applications.

Note: For lighting applications, fuse size is based on ballast manufacturer's recommendations, typically 1 to 3 amp max.

PROJECT:

TYPE:

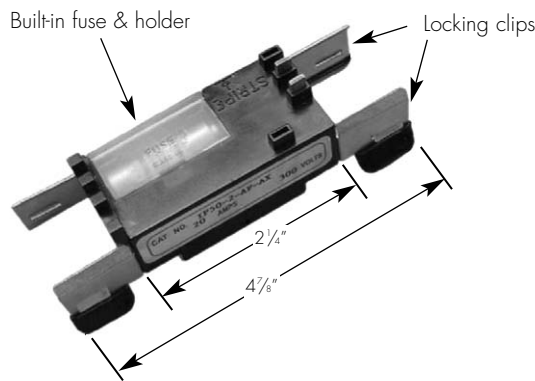

Mounted directly to light fixture

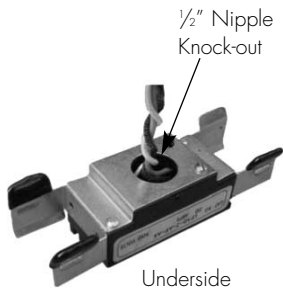

Underside



Concealed in Busway



### ORDERING INFORMATION:

Model	Description	Weight
IP50-20-A	20 amp, non-fusible, 2 pole, A phase	0.5 lb
IP50-20-B	20 amp, non-fusible, 2 pole, B phase	0.5 lb
IP50-20-C	20 amp, non-fusible, 2 pole, C phase	0.5 lb
IP50-20-(Y)F	20 amp, with fuse, 2 pole	0.5 lb
IP50-30-A	30 amp, non-fusible, 2 pole, A phase	0.5 lb
IP50-30-B	30 amp, non-fusible, 2 pole, B phase	0.5 lb
IP50-30-C	30 amp, non-fusible, 2 pole, C phase	0.5 lb
IP50-30-(Y)F	30 amp, with fuse, 2 pole	0.5 lb
IP50-30-4	30 amp, non-fusible, 4 pole	0.5 lb

Example: IP50-30-B

Cat #:

### Catalog Number Sequence

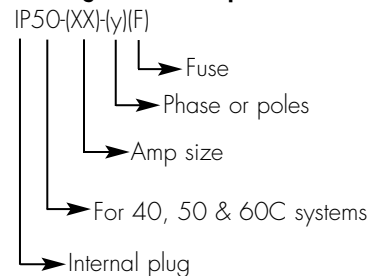

# COMPACT BUSWAY

## FOR SUSPENDED CEILINGS

B 4 0 , B 5 0 &  
B 6 0 C  
S U S P E N D E D  
C E I L I N G S

Busway sections (shown in grey bold) are available in 20, 10 and 5 ft lengths for three standard drop or suspended ceiling configurations.

### Dry Wall

Add "R" for "recessed" to basic housing part number. Example: B50R-20-4 for a 20ft section of B50, 4-pole housing.

### Standard Tile

Add "R" for "recessed" to basic housing part number. Example: B50R-20-4 for a 20ft section of B50, 4-pole housing.

### Tegular Tile

Add "R" for "recessed" to basic housing part number. Example: B50R-20-4 for a 20ft section of B50, 4-pole housing.

PROJECT :  
  
TYPE :

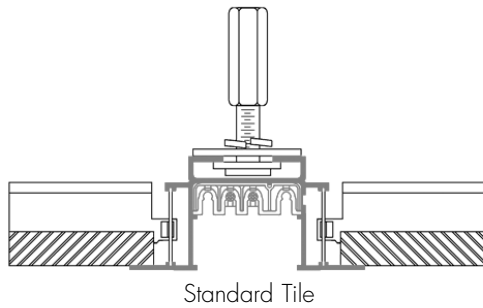
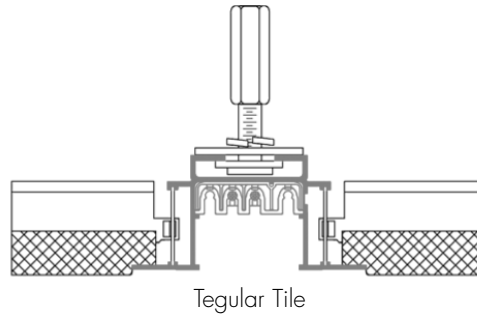
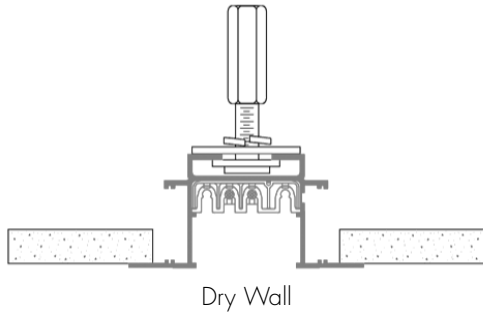

### ORDERING INFORMATION:

Model	Description	Length*
B40R-5-2 or 4	Recessed Housing 40 amp, 2 or 4 pole	5'
B40R-10-2 or 4	Recessed Housing 40 amp, 2 or 4 pole	10'
B40R-20-2 or 4	Recessed Housing 40 amp, 2 or 4 pole	20'
B50R-5-2 or 4	Recessed Housing 50 amp, 2 or 4 pole	5'
B50R-10-2 or 4	Recessed Housing 50 amp, 2 or 4 pole	10'
B50R-20-2 or 4	Recessed Housing 50 amp, 2 or 4 pole	20'
B60CR-5-2 or 4	Recessed Housing 60 amp, 2 or 4 pole	5'
B60CR-10-2 or 4	Recessed Housing 60 amp, 2 or 4 pole	10'
B60CR-20-2 or 4	Recessed Housing 60 amp, 2 or 4 pole	20'

Example: B50R-20-4

Cat #:

# COMPACT BUSWAY

## GRID LAYOUT

B 40, B 50 &  
B 60 C  
GRID LAYOUT

IT IS HIGHLY RECOMMENDED THAT YOU REQUEST THE ASSISTANCE OF YOUR LOCAL AMERLUX APPLICATIONS SPECIALIST TO ASSIST IN GRID LAYOUT. FINAL LAYOUT AND BILLS OF MATERIAL CAN BE PROVIDED WITH THE ASSISTANCE OF OUR ENGINEERING DEPARTMENT.

PROJECT:  
  
TYPE:

ONE PLANE EXAMPLE      Electrical path in grey bold in parallel directions

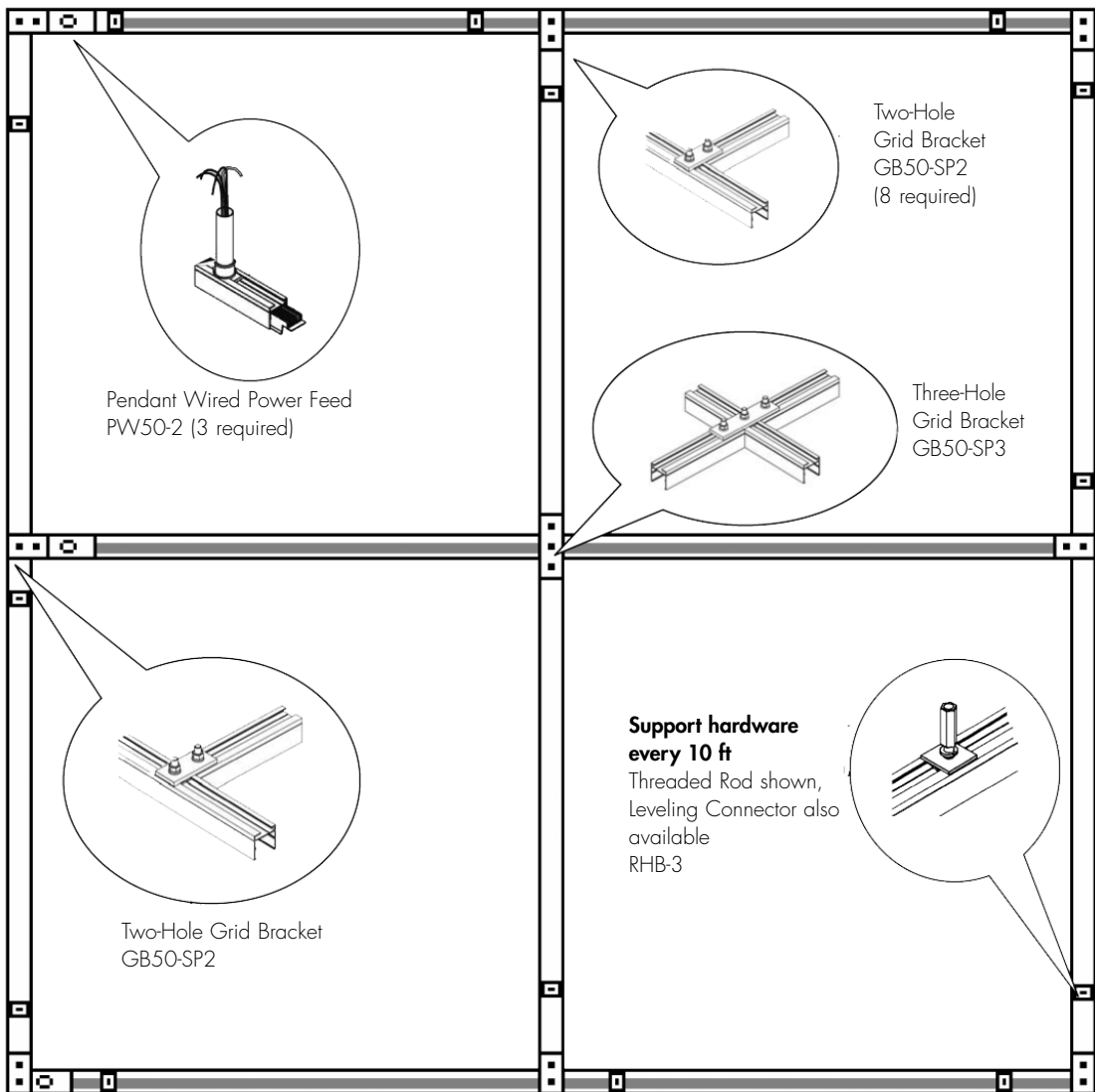

# COMPACT BUSWAY

## GRID LAYOUT

B 40, B 50 &  
B 60 C  
GRID LAYOUT

**IT IS HIGHLY RECOMMENDED THAT YOU REQUEST THE ASSISTANCE OF YOUR LOCAL AMERLUX APPLICATIONS SPECIALIST TO ASSIST IN GRID LAYOUT. FINAL LAYOUT AND BILLS OF MATERIAL CAN BE PROVIDED WITH THE ASSISTANCE OF OUR ENGINEERING DEPARTMENT.**

PROJECT:  
  
TYPE:

ONE PLANE EXAMPLE      Electrical path in grey bold in both directions

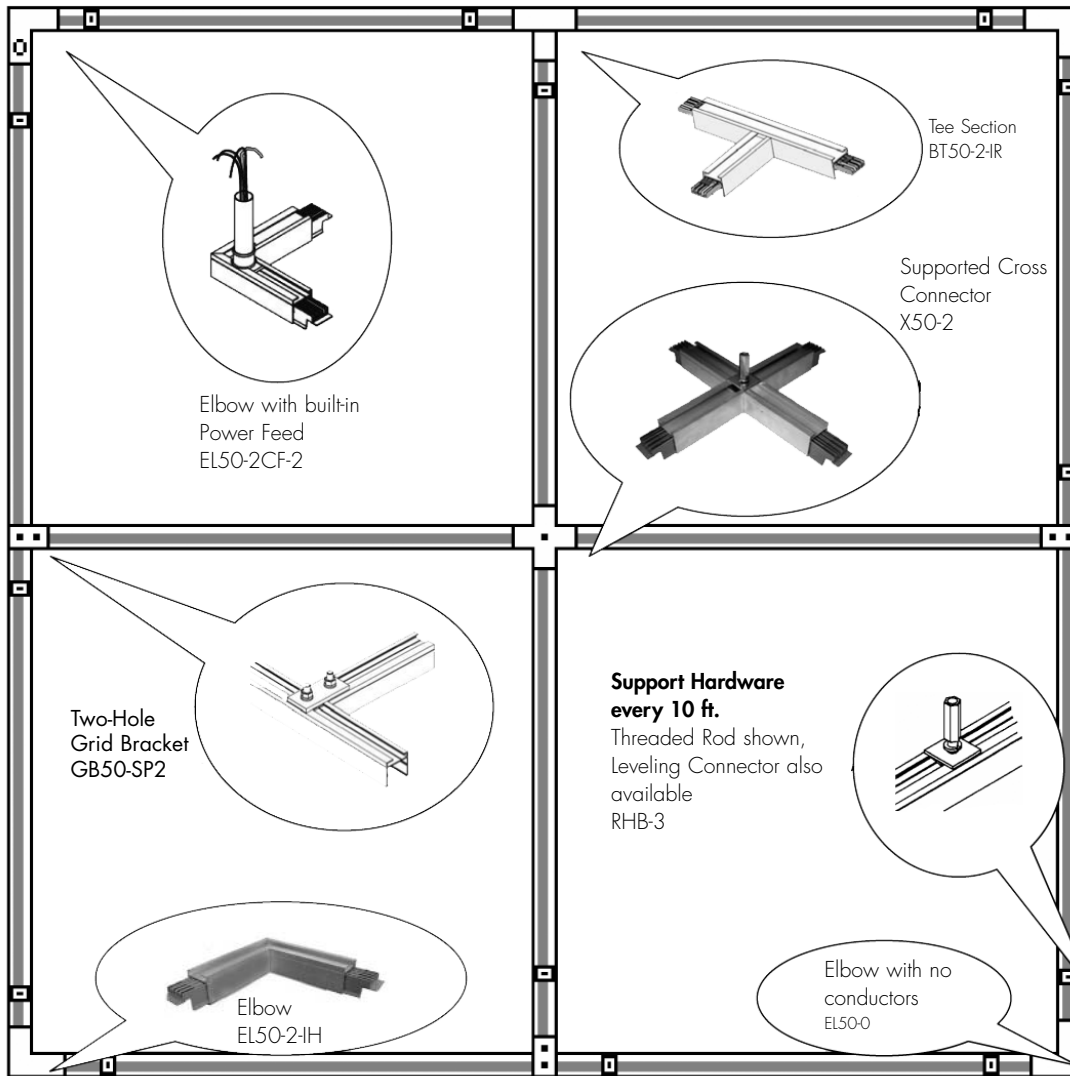

# COMPACT BUSWAY

## GRID LAYOUT

B 40, B 50 &  
B 60 C  
GRID LAYOUT

**IT IS HIGHLY RECOMMENDED THAT YOU REQUEST THE ASSISTANCE OF YOUR LOCAL AMERLUX APPLICATIONS SPECIALIST TO ASSIST IN GRID LAYOUT. FINAL LAYOUT AND BILLS OF MATERIAL CAN BE PROVIDED WITH THE ASSISTANCE OF OUR ENGINEERING DEPARTMENT.**

PROJECT:  
  
TYPE:

TWO PLANE EXAMPLE      Electrical path in grey bold in both directions

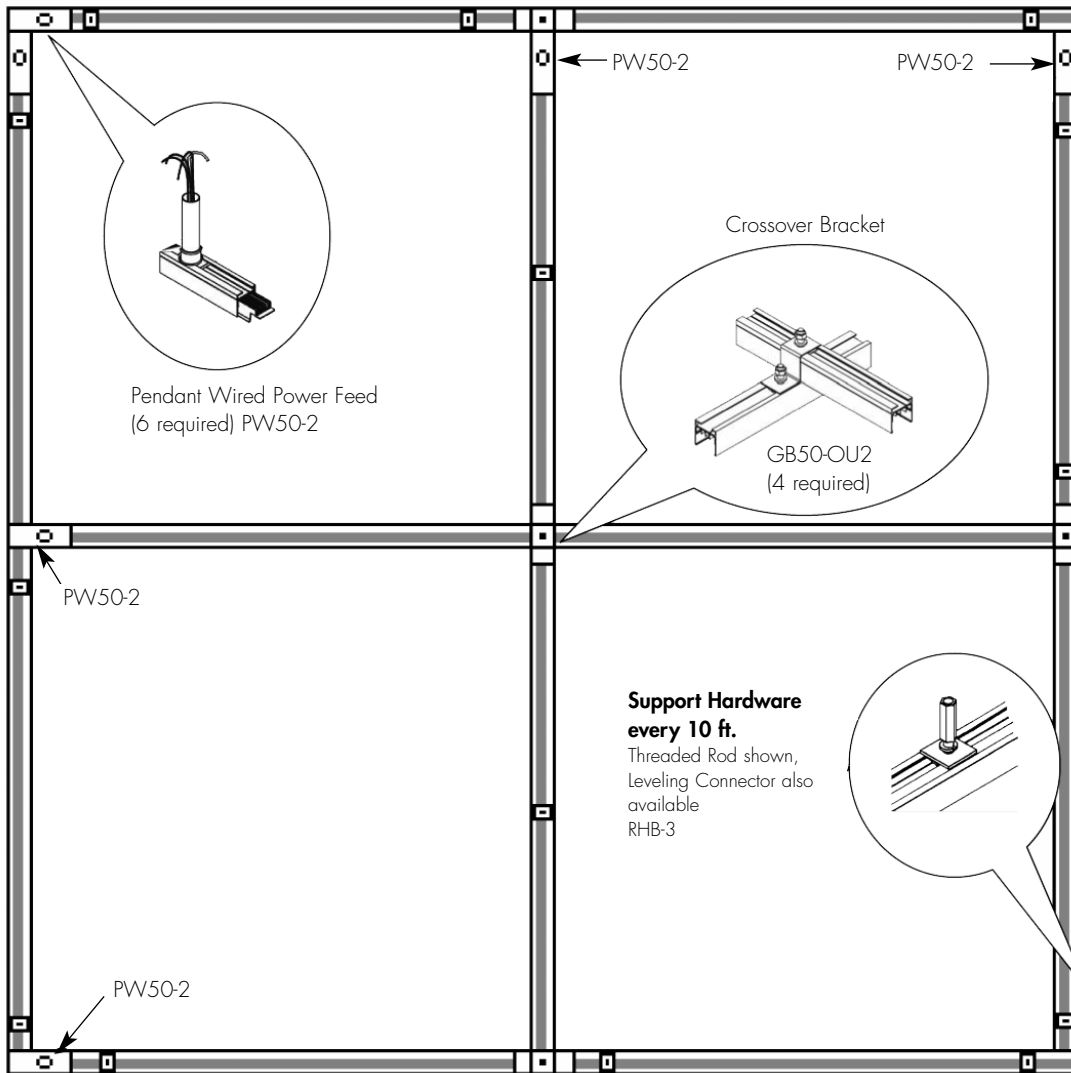

# COMPACT BUSWAY

## GRID LAYOUT

B 4 0 , B 5 0 &  
B 6 0 C  
GRID LAYOUT

### TWO PLANE (OVER-UNDER)

The most economical method for providing single, two or three phase power in both directions. Use simple straight runs with power feeds from either end.

### SINGLE PLANE (Open Ceiling)

Can provide single, two-phase or three-phase power on the same plane over the entire grid layout (in both directions) or in one direction only. Ideal for isolating assigned grid sections.

### SINGLE PLANE (Drop Ceiling)

T-Bar ceiling extrusion is designed to replace the main runner of T-Bar ceilings. Extrusion allows for hardware, joining hardware and t-bar clips and accept cross-t's of the acoustical tile system. Use in SINGLE PLANE applications by substituting the standard B40, B50 or B60C housing with the designation "R" as in B40R. All other components remain the same.

PROJECT :

TYPE :

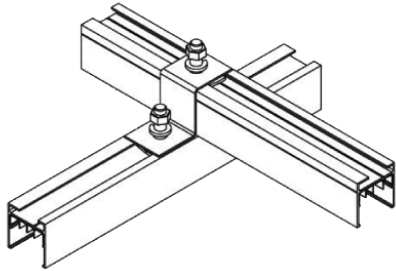

TWO PLANE (OVER-UNDER)

Electrical path

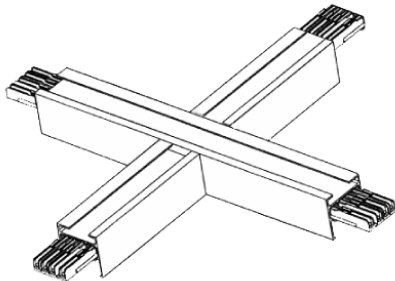
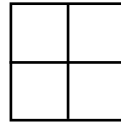

SINGLE PLANE (OPEN CEILING)

Electrical path

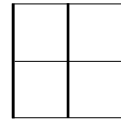

or

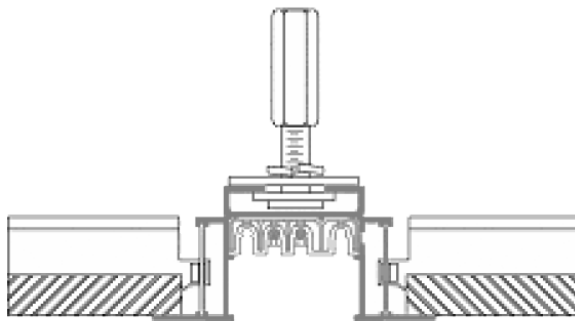
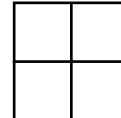

SINGLE PLANE (DROP CEILING)



# COMPACT BUSWAY

GRID CONNECTORS, ELBOWS

B 40, B 50 &  
B 60 C  
GRID CONNECTORS,  
ELBOW

IT IS HIGHLY RECOMMENDED THAT YOU REQUEST THE ASSISTANCE OF YOUR LOCAL AMERLUX APPLICATIONS SPECIALIST TO ASSIST IN GRID LAYOUT. FINAL LAYOUT AND BILLS OF MATERIAL WILL BE PROVIDED WITH THE ASSISTANCE OF OUR ENGINEERING DEPARTMENT. SELECTION OF THE PROPER GRID CONNECTORS IS CRITICAL AS ALL SECTIONS OF AMERLUX TRACK BUSWAY ARE POLARIZED TO PREVENT PHASE MISMATCH.

PROJECT:

TYPE:

## Catalog Number Sequence for Elbow Sections used in Grid Layouts

(XX)(XX)-(X)-(XX)

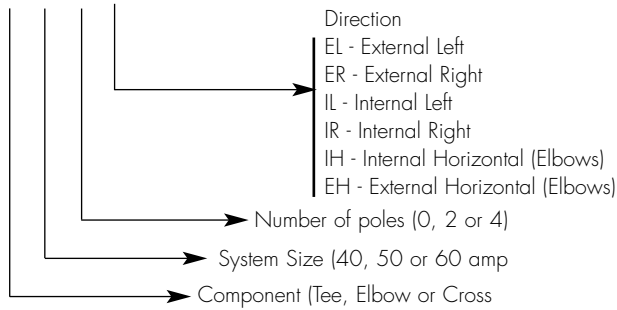

## ELBOWS Electrical Path in grey bold, Polarizing Strip in black bold

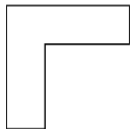

EL50-0

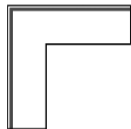

EL50-0-EH

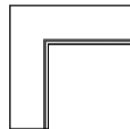

EL50-0-IH

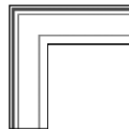

EL(XX)-(X)-EH

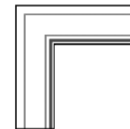

EL(XX)-(X)-IH

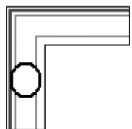

EL(XX)-(X)CF-EH

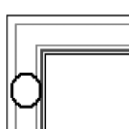

EL(XX)-(X)CF-IH

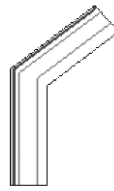

EL(XX)-(X)-EH-45

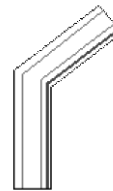

EL(XX)-(X)-IH-45



# COMPACT BUSWAY

## GRID CONNECTORS, TEE'S

B40, B50 &  
B60C  
GRID CONNECTORS,  
TEE'S

IT IS HIGHLY RECOMMENDED THAT YOU REQUEST THE ASSISTANCE OF YOUR LOCAL AMERLUX APPLICATIONS SPECIALIST TO ASSIST IN GRID LAYOUT. FINAL LAYOUT AND BILLS OF MATERIAL WILL BE PROVIDED WITH THE ASSISTANCE OF OUR ENGINEERING DEPARTMENT. SELECTION OF THE PROPER GRID CONNECTORS IS CRITICAL AS ALL SECTIONS OF AMERLUX TRACK BUSWAY ARE POLARIZED TO PREVENT PHASE MISMATCH.

PROJECT:

TYPE:

### Catalog Number Sequence for Tee Sections used in Grid Layouts

(XX)(XX)-(X)-(XX)

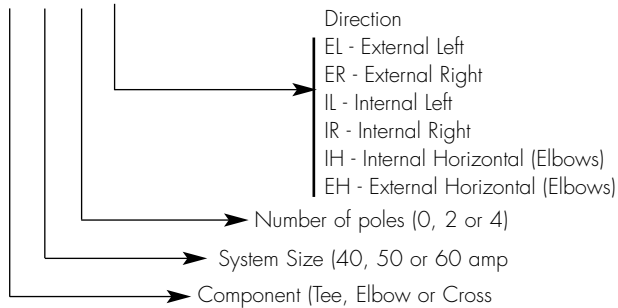

### TEE'S Electrical Path in grey bold, Polarizing Strip in black bold

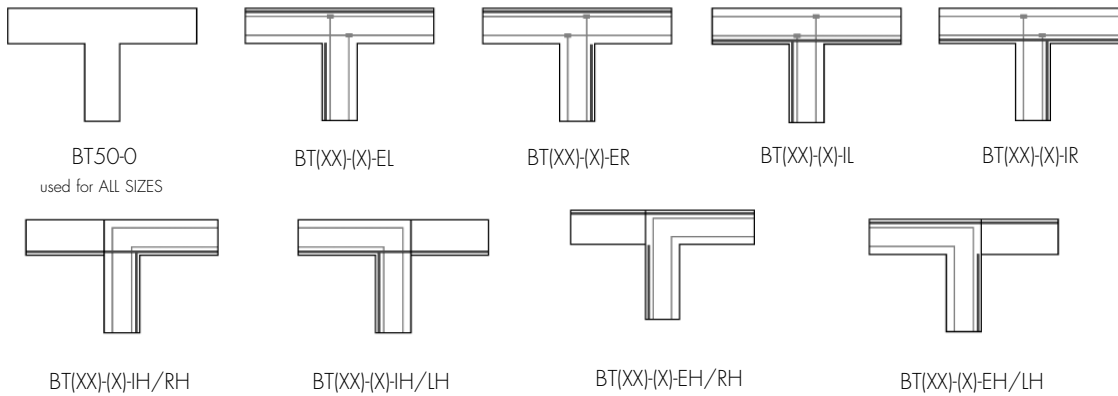

# COMPACT BUSWAY

## GRID CONNECTORS, CROSSOVERS

B40, B50 &  
B60C  
GRID CONNECTORS,  
CROSSOVERS

IT IS HIGHLY RECOMMENDED THAT YOU REQUEST THE ASSISTANCE OF YOUR LOCAL AMERLUX APPLICATIONS SPECIALIST TO ASSIST IN GRID LAYOUT. FINAL LAYOUT AND BILLS OF MATERIAL WILL BE PROVIDED WITH THE ASSISTANCE OF OUR ENGINEERING DEPARTMENT. SELECTION OF THE PROPER GRID CONNECTORS IS CRITICAL AS ALL SECTIONS OF AMERLUX TRACK BUSWAY ARE POLARIZED TO PREVENT PHASE MISMATCH.

PROJECT:

TYPE:

### Catalog Number Sequence for Crossover Sections used in Grid Layouts

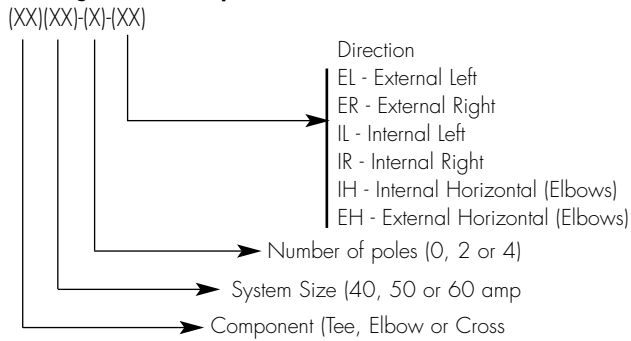

### CROSSOVERS Electrical Path in grey bold, Polarizing Strip in black bold

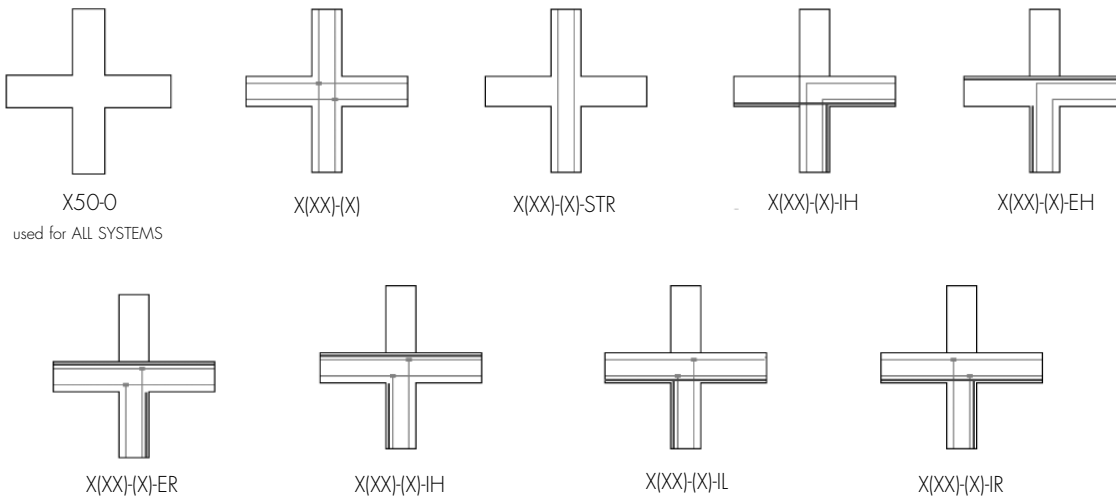

# COMPACT BUSWAY

## GENERAL LAYOUT TIPS

B40, B50 &  
B60C  
GENERAL LAYOUT  
TIPS

Try to keep all runs as straight as possible as tees, elbows and crosses are added cost. With grid or any other bi-directional applications, there is a choice of two-plane with each direction on a separate plane or using Cross Sections if single-plane is required. Single-plane applications can provide power in both directions as well as parallel runs. Please refer to GRID LAYOUT for more detail.

Standard Busway lengths are available in 20, 10 and 5-foot increments. Although the factory can cut individual AMERLUX Track Busway sections to any length under 20 feet, it is highly recommended to keep all layout runs in increments of 5 feet. This recommendation is based on our experience with economics and simplifying job site installation. If housing sections are cut to 3, 4, 6ft, etc it can become cumbersome at the job site to determine which length goes with which run. By staying with 5-foot increments, this condition is minimized.

Determine location of power feeds based on relation to power source, existing feeders and voltage drop concerns for longer runs.

PROJECT :

TYPE :

### LENGTH OF BUSWAY FOR A ONE VOLT DROP IN LINE TO LINE VOLTAGE

SYSTEM DESIGNATION	DISTRIBUTED LOAD	VOLTAGE DROP @ 0.8 PF SINGLE PHASE	VOLTAGE DROP @ 0.8 PF THREE PHASE
B40	40 AMPS	45 FEET	32 FEET
B50	50 AMPS	36 FEET	26 FEET
B60C	60 AMPS	46 FEET	24 FEET

There is no need to be concerned with the specific detail and total count of support hardware, connectors and end caps as your local AMERLUX Track Busway Applications specialist will assist during the quotation process. Refer to SPECIFICATIONS for the suggested AMERLUX specification form.

Understand component relationship before specifying or ordering specific Tee or Elbow Sections. Refer to Component Relationship for details.



# COMPACT BUSWAY

SAMPLE TAKE-OFF

B40, B50 &  
B60C  
SAMPLE TAKE-OFF

**Description:**

**Straight run, 50 Amp system, 80 feet long, 4-pole with End Feed and supported by 3/8" threaded rod.**

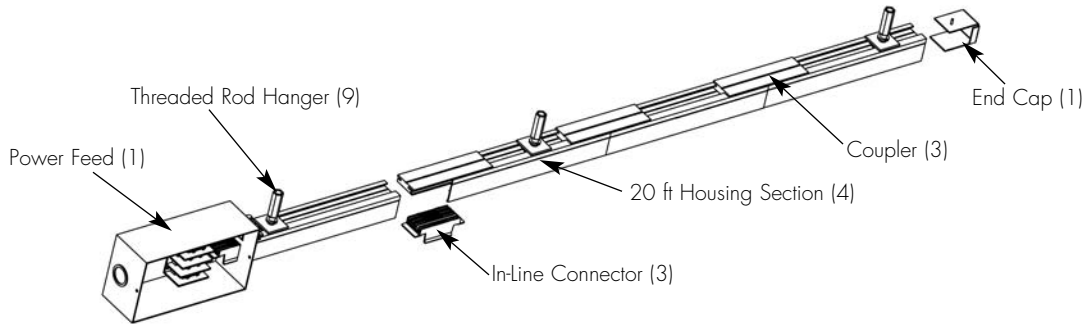

PROJECT :

TYPE :

**BILL OF MATERIAL:**

QTY	PART NO.	DESCRIPTION
4	B50-20-4	Housing Section, 20', 4 Pole
3	BC50-4	In-Line Connector, 4 Pole
3	HC50-2	Housing Coupler, plate type
1	EC50	End Cap
9	RHB-3	3/8" Threaded Rod Hanger
1	EF50-4	End Power Feed, 4 Pole

