

# EVOKE 2.9" ROUND PINHOLE ADJUSTABLE TRIMLESS

E2.9RPATL

MR16

## APPLICATION:

Commercial and retail accent and display lighting

## HOUSING CONSTRUCTION:

20 ga. steel painted matte black  
Formed aperture plate with  $\frac{3}{8}$ " lip  
Cast aluminum plaster frame w/perforated face  
Integral adjustable locking mounting bars  
Thermally protected  
Bi-Pin base

## OPTICS:

Cam adjustment mechanism provides lockable 0-25° tilt; 360°+ rotation  
Spun aluminum lamp holder with spring steel retaining clip, snaps in/out for easy relamping  
Accepts up to 2 accessories  
Solite beam softening lens (standard)

## REFLECTOR CONSTRUCTION:

Die-cast aluminum faceplate painted matte white  
Die-cast knife edge baffle painted matte black  
Spring steel mounting clips

## MOUNTING:

For use in sheet rock ceiling  
Max. ceiling thickness - 1"

## LABELING:

cUL listed  
Damp location

## LAMPING:

MR16 halogen, 50w max., 12v.



PROJECT:

TYPE:

**ECOTECHURAL**

Architectural lighting for sustainable design.

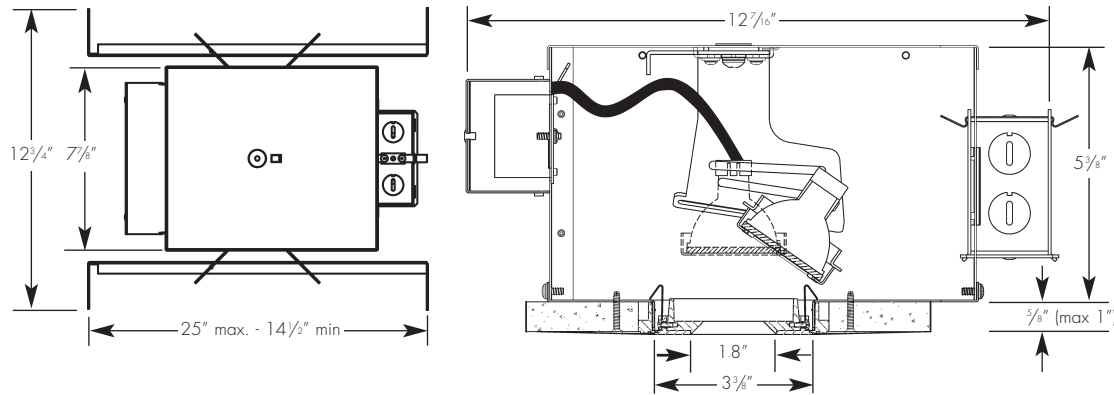

Ceiling cut out dimension: 4 1/16" dia.

## ELECTRICAL

Ballast	Lamping 50w	Input	
		watts	Amps
Electronic 120v	50	.42	
277v	50	.18	

MR16 Bi-Pin base, 50w max.

### Electronic ballast

Amerlux reserves the right to change details that do not affect overall function and performance.

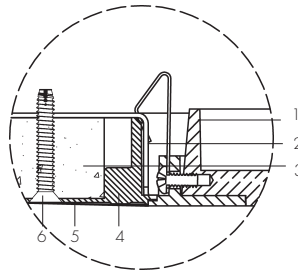

1. Reflector Trim
2. Fixture Housing Aperture Plate
3. Ceiling 5/8" (1" Max.)
4. Cast Aluminum Plaster Frame
5. Plaster Skim Coat (By Others)
6. 6-32 Type F Thread Cutting Screw



**AMERLUX**  
LIGHTING SOLUTIONS

ADAPT. ABILITY.™

## ORDERING INFORMATION:

HOUSING			REFLECTOR		ACCESSORIES
Model #	Lamp Type	Voltage	Model #	Aperture Finish	Ordered Separately
E2.9RATL	MR16 (50w max)	120 277	E2.9RPATL	Faceplate with black baffle MW - matte white	HEX16 - hexcell louver SPR16 - linear spread lens (5"x55")

Complete Unit Specification: E2.9RATL-MR16-120/E2.9RPATL-MW

Housing Only: E2.9RATL-MR16-120

Reflector Only: E2.9RPATL-MW

Cat #: